

technical
parameters

NEO·EII

Electric
Injection Molding Machine

Tederic Machinery Co., Ltd.
No.245 Wenze North Road,
Hangzhou City, Zhejiang Province, 310018, China
T. +86-571-86733387
www.tedericglobal.com

t.NEO·EII.202303.28

tederic
SMART INJECTION

NEO-EII

Parameters

Clamping unit		NEO-E60II					
Clamping force	kN	600					
Clamping stroke	mm	270					
Space between tie bars	mm	360x320					
Max. mold height	mm	380					
Min. mold height	mm	150					
Ejector stroke	mm	60					
Ejector force	kN	24.5					
No. of ejector pins	piece	5					
Max. daylight	mm	650					
Min. mold dimension	mm	250x225					
Platen dimensions (HxV)	mm	545x505					
Injection unit	Unit	e80			e110		
		A	B	C	A	B	C
Screw diameter	mm	20	22	25	22	25	28
Screw L/D ratio	L/D	22.0	20.0	17.6	22.7	20.0	17.9
Shot size (theoretical)	cm ³	30	36	46	40	52	65
Injection weight (PS)	g	27	33	42	36	47	59
Injection pressure	MPa	266	220	170	284	220	175
	kgf/cm ²	2720	2240	1740	2900	2240	1790
Holding pressure	MPa	213	176	136	227	176	140
	kgf/cm ²	2170	1800	1390	2320	1800	1430
Injection rate into air (PS)	g/s	/			/		
Screw speed	rpm	400			400		
Max. injection speed	mm/s	/			/		
Injection stroke	mm	94			105		
Nozzle contact force	kN	11.7			15.7		
Injection unit	Unit	e80h			e110h		
Injection rate into air	g/s	114	138	179	138	179	224
Max. injection speed	mm/s	400			400		
Others	Unit	e80h			e110h		
Total power capacity	kW	20			21		
Heater Power	kW	4.5			5.4		
Hopper Capacity	kg	15			25		
Total machine weight	t	3.6			3.7		
Machine dimension (LxWxH)	m	4.3x1.3x1.9			4.3x1.3x1.9		

Remarks:

Shot size (theoretical) = Cross-sectional area of barrel(cm²) * injection stroke(cm)

Injection Weight = Shot size (theoretical)*0.91 (0.91 is the density of PS material)

Injection Weight and Injection rate into air is depends on material and parameters settings. The data in the table is for reference.

The injection pressure in the table is the maximum you can set. The truth data can be set as per your requirement.

Please inform us if you have requirement for engineering material like PVC, PMMA or some special requirement.

Due to continuous improvements, we reserve the right to modify any aspect of the specification without prior notice.

Front view of machine dimension

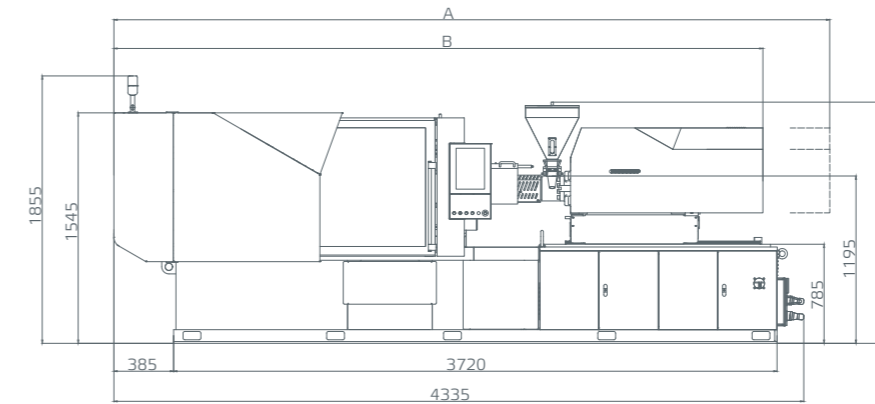

Top view of machine dimension

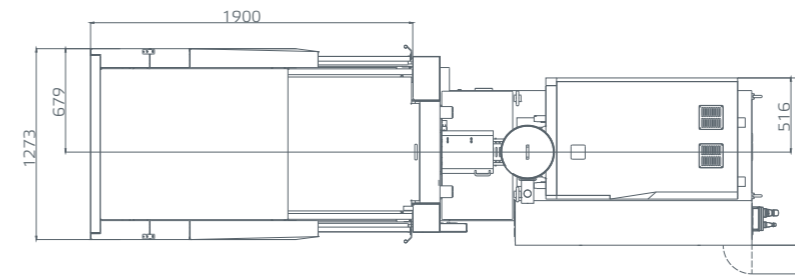

Moving platen dimension

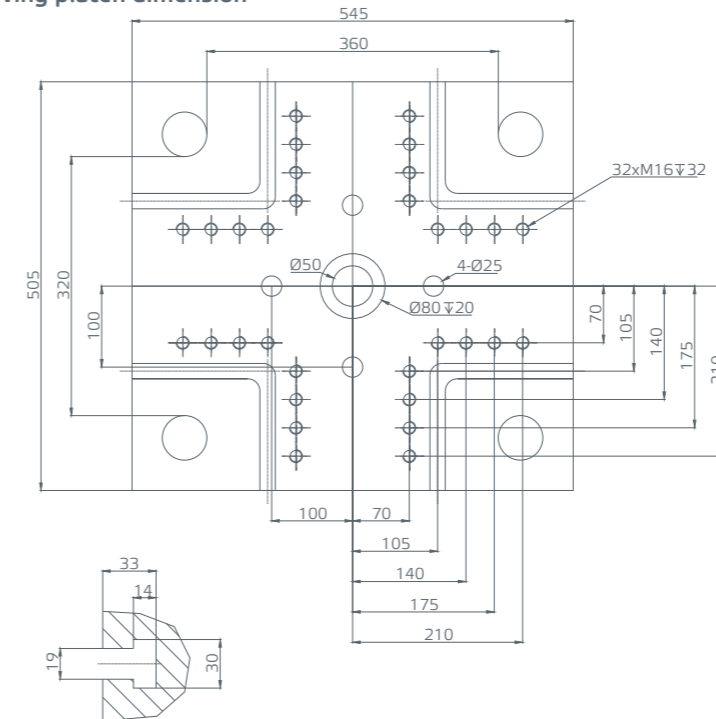

Robot installation dimension

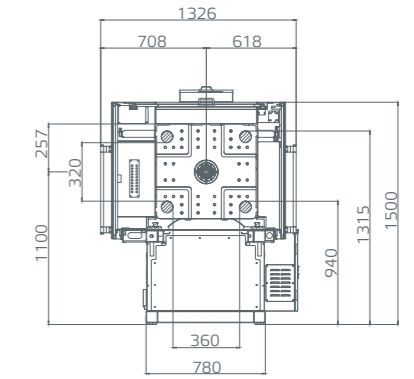

Robot fixed platen dimension

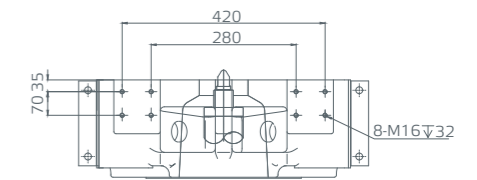

Feeding port dimensions

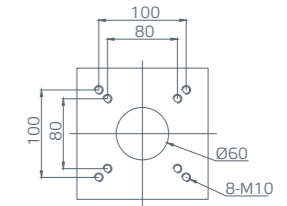

Clamping unit

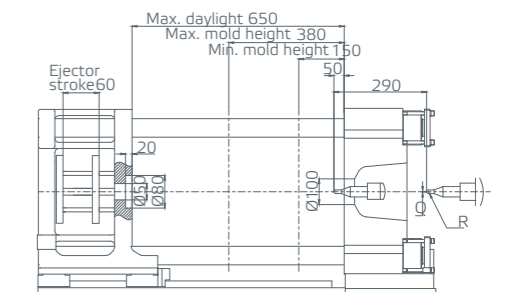

Injection unit	A	B	Q	R
e80h	4025	3735	Ø2.5	SR10
e110h	4080	3790	Ø2.5	SR10

Unit:mm

Parameters

Clamping unit		NEO-E90II								
Clamping force	kN	900								
Clamping stroke	mm	320								
Space between tie bars	mm	420x360								
Max. mold height	mm	410								
Min. mold height	mm	150								
Ejector stroke	mm	80								
Ejector force	kN	24.5								
No. of ejector pins	piece	5								
Max. daylight	mm	730								
Min. mold dimension	mm	295x250								
Platen dimensions (HxV)	mm	610x550								
Injection unit	Unit	e110			e160			e220		
		A	B	C	A	B	C	A	B	C
Screw diameter	mm	22	25	28	25	28	32	28	32	35
Screw L/D ratio	L/D	22.7	20.0	17.9	22.4	20.0	17.5	23.0	20.0	18.3
Shot size (theoretical)	cm ³	40	52	65	59	74	97	83	109	130
Injection weight (PS)	g	36	47	59	54	67	88	76	99	118
Injection pressure	MPa	284	220	175	276	220	168	261	200	167
	kgf/cm ²	2900	2240	1790	2820	2240	1720	2670	2040	1710
Holding pressure	MPa	227	176	140	221	176	135	209	160	134
	kgf/cm ²	2320	1800	1430	2250	1800	1380	2130	1630	1360
Injection rate into air (PS)	g/s	/	/	/	80	112	147	112	147	175
Screw speed	rpm	400			400			400		
Max. injection speed	mm/s	/			200			200		
Injection stroke	mm	105			120			135		
Nozzle contact force	kN	15.7			21.5			21.5		
Injection unit	Unit	e110h			e160h			e220h		
Injection rate into air	g/s	138	179	224	179	224	293	224	293	350
Max. injection speed	mm/s	400			400			400		
Others	Unit	e110h			e160/e160h			e220/e220h		
Total power capacity	kW	21			18/ 27			23/ 38		
Heater Power	kW	5.4			6.3			7.9		
Hopper Capacity	kg	25			25			25		
Total machine weight	t	4.1			4.3			4.4		
Machine dimension (LxWxH)	m	4.5x1.4x1.9			4.5x1.4x1.9			4.5x1.4x1.9		

Remarks:

Shot size (theoretical) = Cross-sectional area of barrel(cm²) * injection stroke(cm)

Injection Weight = Shot size (theoretical)*0.91 (0.91 is the density of PS material)

Injection Weight and Injection rate into air is depends on material and parameters settings. The data in the table is for reference.

The injection pressure in the table is the maximum you can set. The truth data can be set as per your requirement.

Please inform us if you have requirement for engineering material like PVC, PMMA or some special requirement.

Due to continuous improvements, we reserve the right to modify any aspect of the specification without prior notice.

Front view of machine dimension

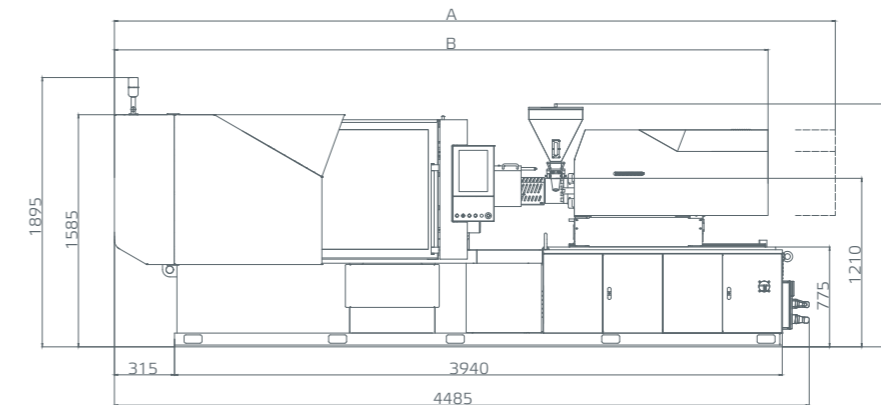

Top view of machine dimension

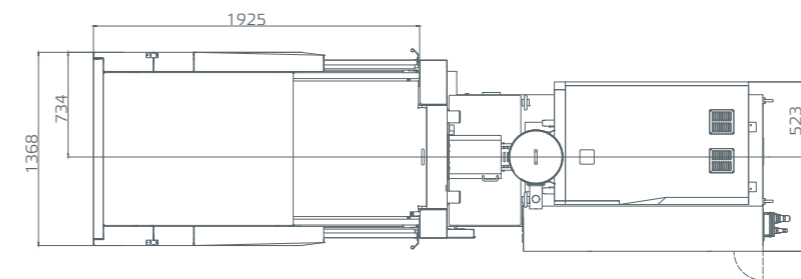

Moving platen dimension

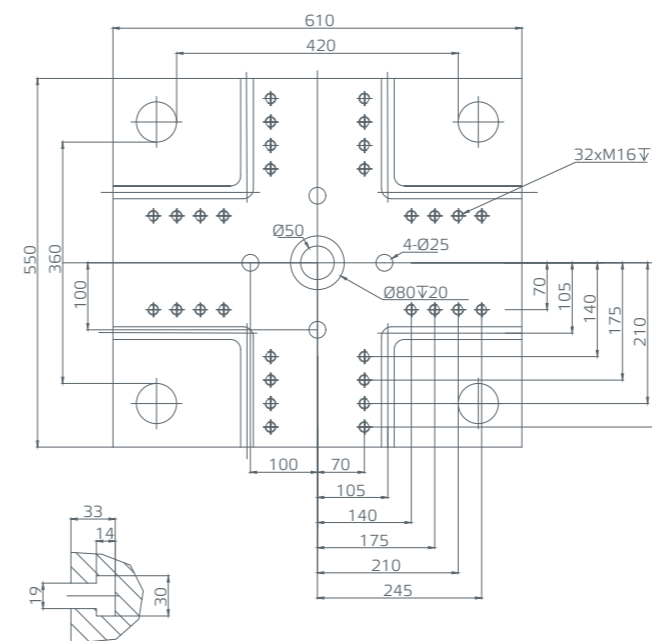

Robot installation dimension

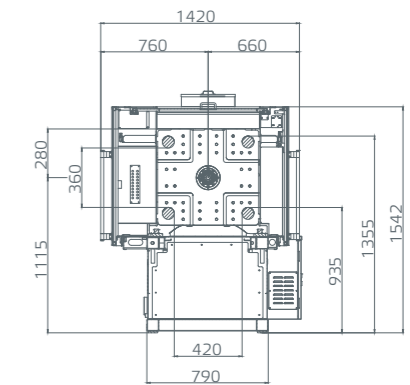

Robot fixed platen dimension

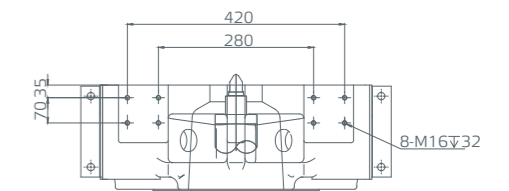

Feeding port dimensions

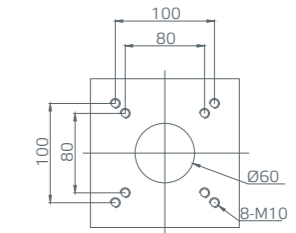

Clamping unit

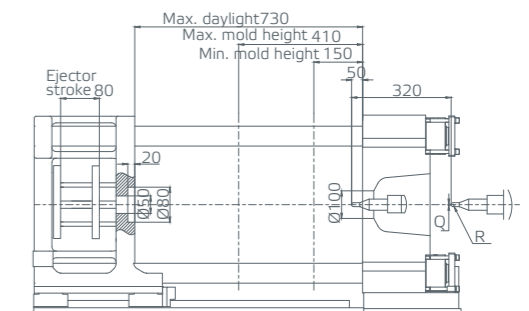

Injection unit	A	B	Q	R
e110h	4237	3917	Ø2.5	SR10
e160h/e160	4317	3997	Ø2.5	SR10
e220h/e220	4427	4107	Ø3	SR10

Unit:mm

Parameters

Clamping unit		NEO-E120II								
Clamping force	kN	1200								
Clamping stroke	mm	360								
Space between tie bars	mm	470x420								
Max. mold height	mm	480								
Min. mold height	mm	160								
Ejector stroke	mm	100								
Ejector force	kN	44								
No. of ejector pins	piece	5								
Max. daylight	mm	840								
Min. mold dimension	mm	330x295								
Platen dimensions (HxV)	mm	710x660								
Injection unit		e160			e220			e360		
	Unit	A	B	C	A	B	C	A	B	C
Screw diameter	mm	25	28	32	28	32	35	35	38	42
Screw L/D ratio	L/D	22.4	20.0	17.5	23.0	20.0	18.3	21.7	20.0	18.1
Shot size (theoretical)	cm ³	59	74	97	83	109	130	154	181	222
Injection weight (PS)	g	54	67	88	76	99	118	140	165	202
Injection pressure	MPa	276	220	168	261	200	167	236	200	164
	kgf/cm ²	2820	2240	1720	2670	2040	1710	2410	2040	1670
Holding pressure	MPa	221	176	135	209	160	134	189	160	131
	kgf/cm ²	2250	1800	1380	2130	1630	1360	1920	1630	1340
Injection rate into air (PS)	g/s	80	112	147	112	147	175	175	206	252
Screw speed	rpm	400			400			400		
Max. injection speed	mm/s	200			200			200		
Injection stroke	mm	120			135			160		
Nozzle contact force	kN	82			82			82		
Injection unit		e160h			e220h			e360h		
Injection rate into air	g/s	179	224	293	224	293	350	350	413	504
Max. injection speed	mm/s	400			400			400		
Others		e160h/e160h			e220/e220h			e360/e360h		
Max. pump pressure	Mpa	17.5			17.5			17.5		
Pump motor power	kW	11			11			11		
Total power capacity	kW	18/27			23/38			31.6/41		
Heater power	kW	6.3			7.9			10.6		
Hopper capacity	kg	25			25			25		
Oil tank capacity	L	80			80			80		
Total machine weight	t	5.9			6			6.3		
Machine dimension (LxWxH)	m	4.9x1.5x2.1			4.9x1.5x2.1			5.1x1.5x2.1		

Remarks:

Shot size (theoretical) = Cross-sectional area of barrel(cm²) * injection stroke(cm)

Injection Weight = Shot size (theoretical)*0.91 (0.91 is the density of PS material)

Injection Weight and Injection rate into air is depends on material and parameters settings. The data in the table is for reference.

The injection pressure in the table is the maximum you can set. The truth data can be set as per your requirement.

Please inform us if you have requirement for engineering material like PVC, PMMA or some special requirement.

Due to continuous improvements, we reserve the right to modify any aspect of the specification without prior notice.

Front view of machine dimension

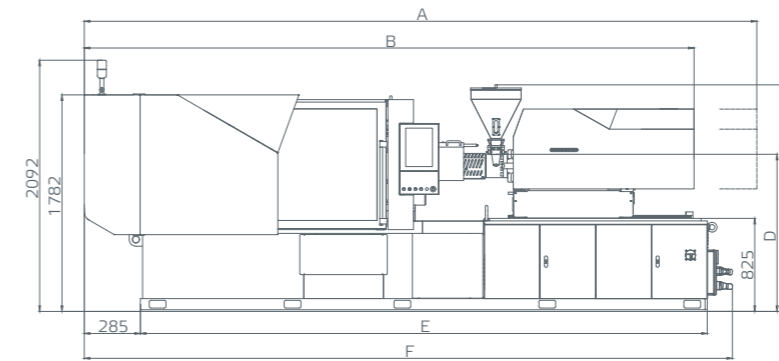

Top view of machine dimension

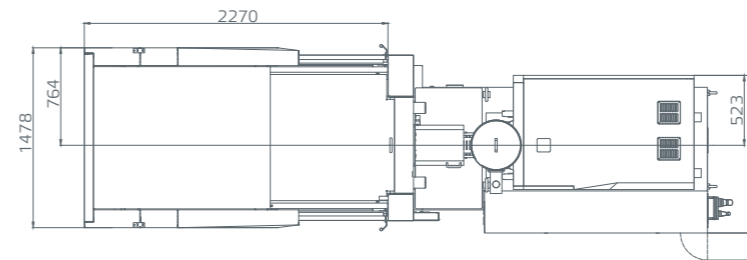

Moving platen dimension

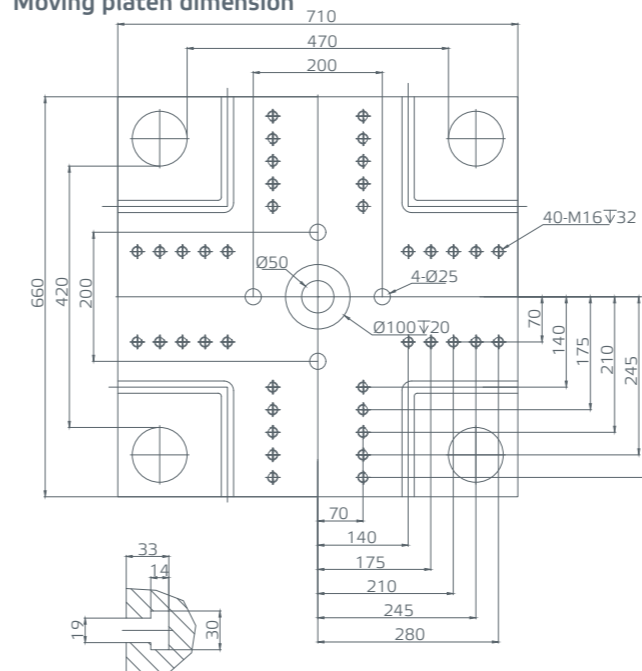

Robot installation dimension

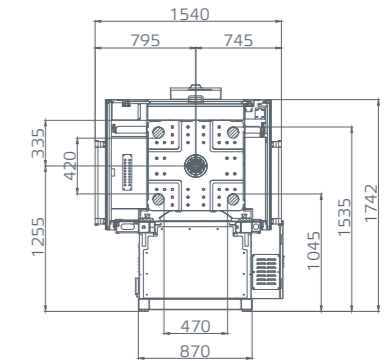

Robot fixed platen dimension

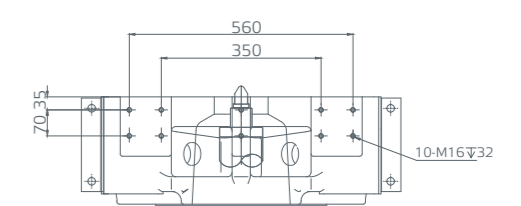

Feeding port dimensions

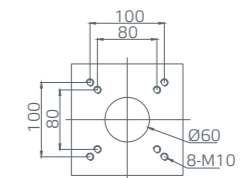

Clamping unit

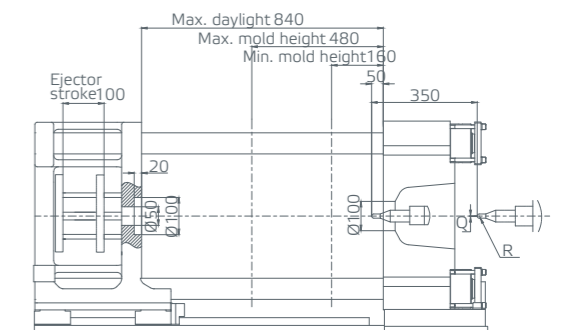

Injection unit	A	B	C	D	E	F	Q	R
e160/e160h	4690	4340	1945	1320	4380	4895	Ø2.5	SR10
e220/e220h	4803	4453	1945	1320	4380	4895	Ø3	SR10
e360/e360h	5155	4805	1985	1365	4610	5125	Ø3	SR10

Unit:mm

NEO-EII

Parameters

Clamping unit		NEO-E160II								
Clamping force	kN	1600								
Clamping stroke	mm	400								
Space between tie bars	mm	520x460								
Max. mold height	mm	530								
Min. mold height	mm	200								
Ejector stroke	mm	120								
Ejector force	kN	56								
No. of ejector pins	piece	5								
Max. daylight	mm	930								
Min. mold dimension	mm	365x320								
Platen dimensions (HxV)	mm	770x720								
Injection unit	Unit	e360			e500			e620		
		A	B	C	A	B	C	A	B	C
Screw diameter	mm	35	38	42	38	42	45	42	45	50
Screw L/D ratio	L/D	21.7	20.0	18.1	22.1	20.0	18.7	21.4	20.0	18.0
Shot size (theoretical)	cm ³	154	181	222	204	249	286	270	310	383
Injection weight (PS)	g	140	165	202	186	227	261	246	282	348
Injection pressure	MPa	236	200	164	244	200	174	230	200	162
	kgf/cm ²	2410	2040	1670	2490	2040	1780	2340	2040	1650
Holding pressure	MPa	189	160	131	195	160	139	184	160	130
	kgf/cm ²	1920	1630	1340	1990	1630	1420	1870	1630	1320
Injection rate into air (PS)	g/s	175	206	252	206	252	289	252	289	357
Screw speed	rpm	400			375			375		
Max. injection speed	mm/s	200			200			200		
Injection stroke	mm	160			180			195		
Nozzle contact force	kN	82			82			82		
Injection unit	Unit	e360h			e500h			e620h		
Injection rate into air	g/s	350	413	504	413	504	579	504	579	715
Max. injection speed	mm/s	400			400			400		
Others	Unit	e360/e360h			e500/e500h			e620/e620h		
Max. pump pressure	Mpa	17.5			17.5			17.5		
Pump motor power	kW	11			11			11		
Total power capacity	kW	31.6/41			36/67			38/68		
Heater power	kW	10.6			13.0			14.0		
Hopper capacity	kg	25			25			25		
Oil tank capacity	L	80			80			80		
Total machine weight	t	7.6			8			8.1		
Machine dimension (LxWxH)	m	5.3x1.5x2.2			5.7x1.5x2.2			5.7x1.5x2.2		

Remarks:

Shot size (theoretical) = Cross-sectional area of barrel(cm²) * injection stroke(cm)

Injection Weight = Shot size (theoretical)*0.91 (0.91 is the density of PS material)

Injection Weight and Injection rate into air is depends on material and parameters settings. The data in the table is for reference.

The injection pressure in the table is the maximum you can set. The truth data can be set as per your requirement.

Please inform us if you have requirement for engineering material like PVC, PMMA or some special requirement.

Due to continuous improvements, we reserve the right to modify any aspect of the specification without prior notice.

Front view of machine dimension

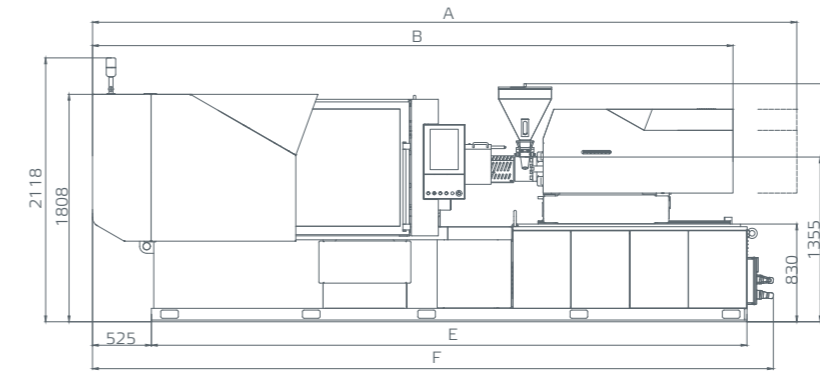

Top view of machine dimension

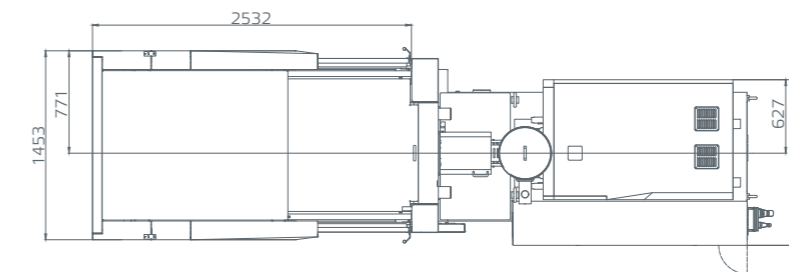

Moving platen dimension

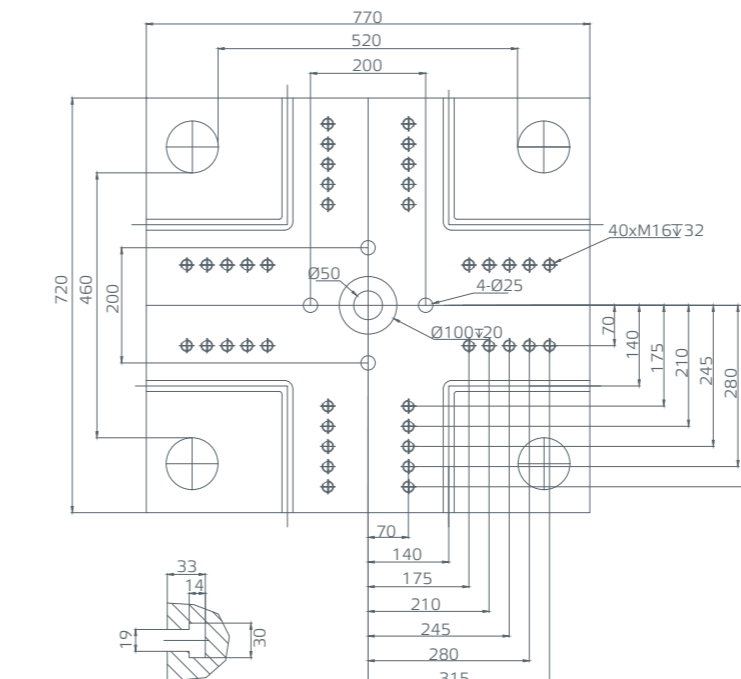

Robot installation dimension

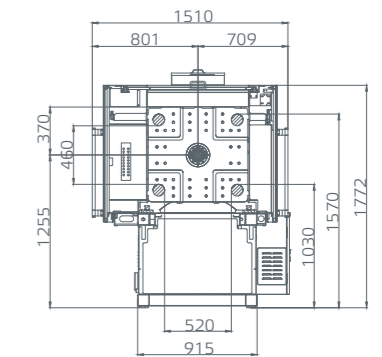

Robot fixed platen dimension

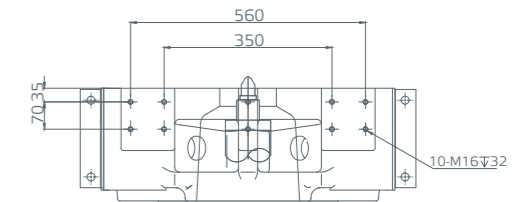

Feeding port dimensions

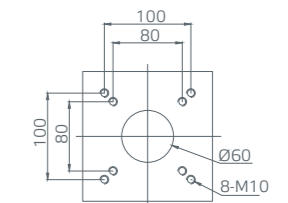

Clamping unit

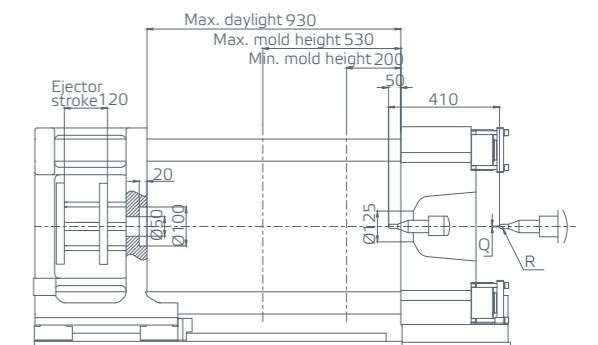

Injection unit	A	B	E	F	Q	R
e360/e360h	5451	5041	4525	5280	Ø3	SR10
e500/e500h	5695	5285	4875	5630	Ø3	SR10
e620/e620h	5753	5343	4875	5630	Ø3	SR10

Unit:mm

NEO-EII

Parameters

Clamping unit		NEO-E200II								
Clamping force	kN	2000								
Clamping stroke	mm	450								
Space between tie bars	mm	570x510								
Max. mold height	mm	560								
Min. mold height	mm	220								
Ejector stroke	mm	150								
Ejector force	kN	56								
No. of ejector pins	piece	7								
Max. daylight	mm	1010								
Min. mold dimension	mm	385x355								
Platen dimensions (HxV)	mm	850x800								
Injection unit	Unit	e500			e620			e840		
		A	B	C	A	B	C	A	B	C
Screw diameter	mm	38	42	45	42	45	50	45	50	55
Screw L/D ratio	L/D	22.1	20.0	18.7	21.4	20.0	18.0	22.2	20.0	18.2
Shot size (theoretical)	cm ³	204	249	286	270	310	383	342	422	511
Injection weight (PS)	g	186	227	261	246	282	348	311	384	465
Injection pressure	MPa	244	220	174	230	200	162	247	200	165
	kgf/cm ²	2490	2040	1780	2340	2040	1650	2520	2040	1690
Holding pressure	MPa	195	160	139	184	160	130	198	160	132
	kgf/cm ²	1990	1630	1420	1870	1630	1320	2020	1630	1350
Injection rate into air (PS)	g/s	206	252	289	252	289	357	232	286	346
Screw speed	rpm	375			375			300		
Max. injection speed	mm/s	200			200			160		
Injection stroke	mm	180			195			215		
Nozzle contact force	kN	82			82			82		
Injection unit	Unit	e500h			e620h			e840h		
Injection rate into air	g/s	413	504	579	504	579	715	434	536	649
Max. injection speed	mm/s	400			400			300		
Others	Unit	e500/e500h			e620/e620h			e840/e840h		
Max. pump pressure	Mpa	17.5			17.5			17.5		
Pump motor power	kW	11			11			11		
Total power capacity	kW	34/67			38/68			61/75		
Heater power	kW	13.0			14.0			18.7		
Hopper capacity	kg	25			25			50		
Oil tank capacity	L	80			80			80		
Total machine weight	t	8.8			8.9			9.9		
Machine dimension (LxWxH)	m	5.9x1.6x2.3			5.9x1.6x2.3			6.3x1.6x2.3		

Remarks:

Shot size (theoretical) = Cross-sectional area of barrel(cm²) * injection stroke(cm)

Injection Weight = Shot size (theoretical)*0.91 (0.91 is the density of PS material)

Injection Weight and Injection rate into air is depends on material and parameters settings. The data in the table is for reference.

The injection pressure in the table is the maximum you can set. The truth data can be set as per your requirement.

Please inform us if you have requirement for engineering material like PVC, PMMA or some special requirement.

Due to continuous improvements, we reserve the right to modify any aspect of the specification without prior notice.

Front view of machine dimension

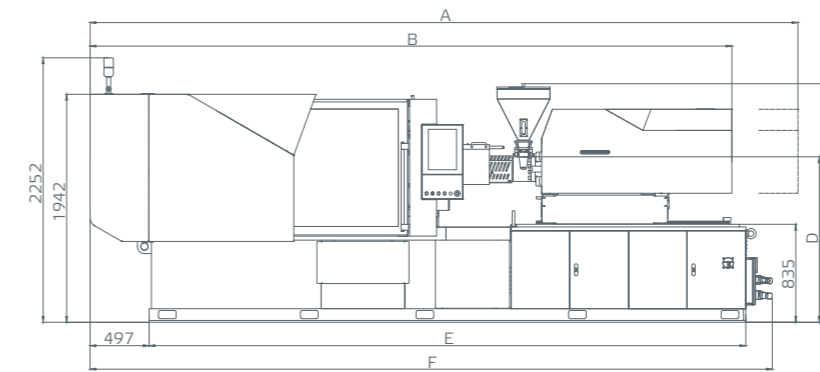

Top view of machine dimension

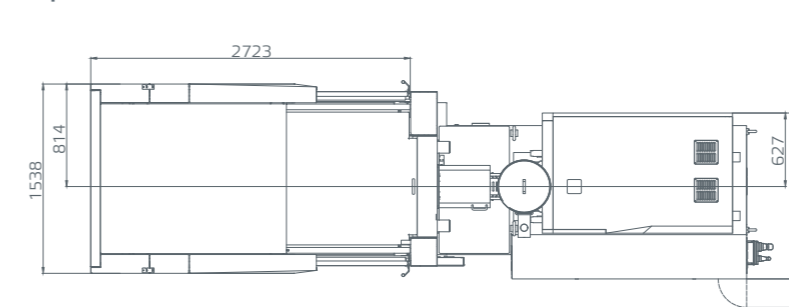

Moving platen dimension

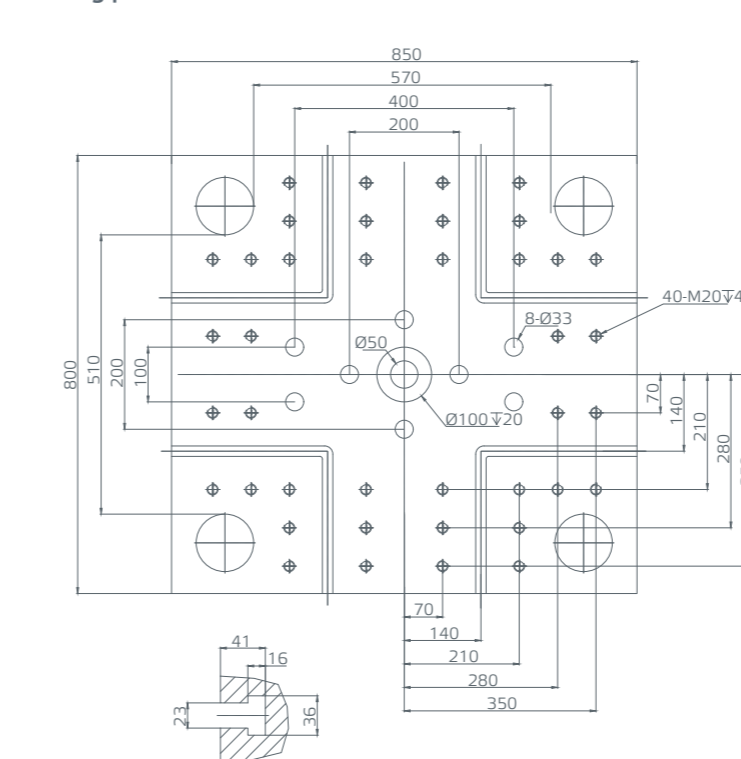

Robot installation dimension

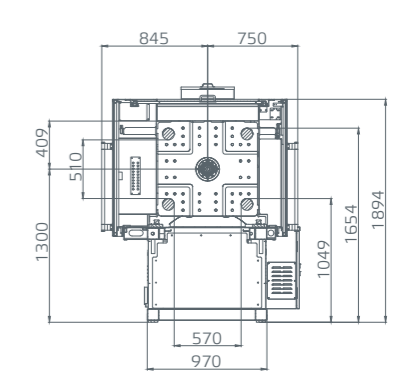

Robot fixed platen dimension

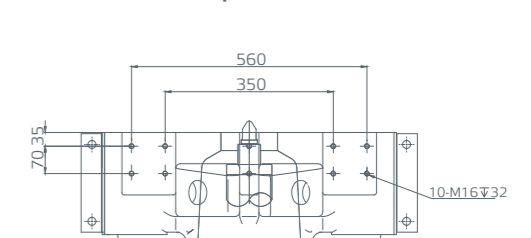

Feeding port dimensions

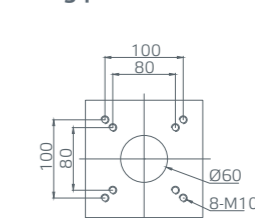

Clamping unit

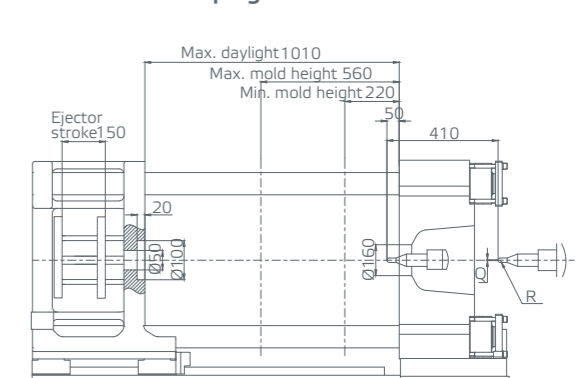

Injection unit	A	B	C	D	E	F	Q	R
e500/e500h	5880	5470	2035	1410	5085	5812	Ø3	SR10
e620/e620h	5940	5530	2035	1410	5085	5812	Ø3	SR10
e840/e840h	6425	6015	2180	1430	5585	6222	Ø4	SR15

Unit:mm

Parameters

Clamping unit		NEO-E260II								
Clamping force	kN	2600								
Clamping stroke	mm	550								
Space between tie bars	mm	630x560								
Max. mold height	mm	600								
Min. mold height	mm	250								
Ejector stroke	mm	150								
Ejector force	kN	68								
No. of ejector pins	piece	7								
Max. daylight	mm	1150								
Min. mold dimension	mm	440x390								
Platen dimensions (HxV)	mm	920x890								
Injection unit		e620			e840			e1100		
	Unit	A	B	C	A	B	C	A	B	C
Screw diameter	mm	42	45	50	45	50	55	50	55	60
Screw L/D ratio	L/D	21.4	20.0	18.0	22.2	20.0	18.2	22.0	20.0	18.3
Shot size (theoretical)	cm ³	270	310	383	342	422	511	471	570	679
Injection weight (PS)	g	246	282	348	311	384	465	429	519	618
Injection pressure	MPa	230	200	162	247	200	165	224	185	155
	kgf/cm ²	2340	2040	1650	2520	2040	1690	2280	1890	1590
Holding pressure	MPa	184	160	130	198	160	132	179	148	124
	kgf/cm ²	1870	1630	1320	2020	1630	1350	1830	1510	1270
Injection rate into air (PS)	g/s	252	289	357	232	286	346	286	346	412
Screw speed	rpm	375			300			350		
Max. injection speed	mm/s	200			160			160		
Injection stroke	mm	195			215			240		
Nozzle contact force	kN	82			82			82		
Injection unit		e620h			e840h			e1100h		
Injection rate into air	g/s	504	579	715	434	536	649	536	649	772
Max. injection speed	mm/s	400			300			300		
Others		e620/e620h			e840/e840h			e1100/e1100h		
Max. pump pressure	Mpa	17.5			17.5			17.5		
Pump motor power	kW	11			11			11		
Total power capacity	kW	38/68			61/75			62/92		
Heater power	kW	14.0			18.7			20.4		
Hopper capacity	kg	25			50			50		
Oil tank capacity	L	80			80			80		
Total machine weight	t	10.7			11.9			12.4		
Machine dimension (LxWxH)	m	6.2x1.7x2.3			6.7x1.7x2.3			6.7x1.7x2.3		

Remarks:

Shot size (theoretical) = Cross-sectional area of barrel(cm²) * injection stroke(cm)

Injection Weight = Shot size (theoretical)*0.91 (0.91 is the density of PS material)

Injection Weight and Injection rate into air is depends on material and parameters settings. The data in the table is for reference.

The injection pressure in the table is the maximum you can set. The truth data can be set as per your requirement.

Please inform us if you have requirement for engineering material like PVC, PMMA or some special requirement.

Due to continuous improvements, we reserve the right to modify any aspect of the specification without prior notice.

Front view of machine dimension

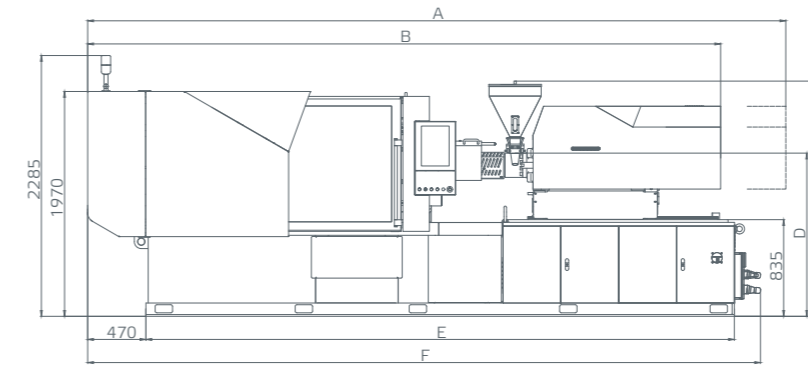

Robot installation dimension

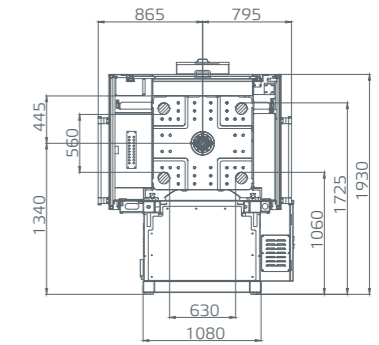

Top view of machine dimension

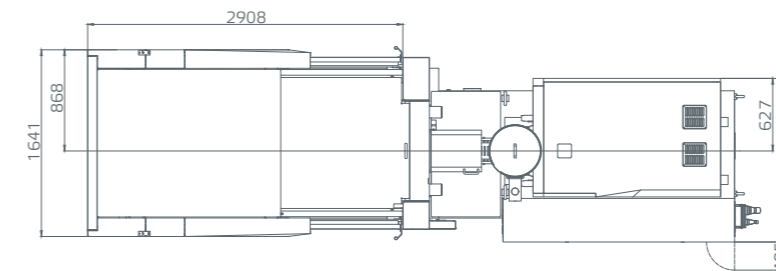

Robot fixed platen dimension

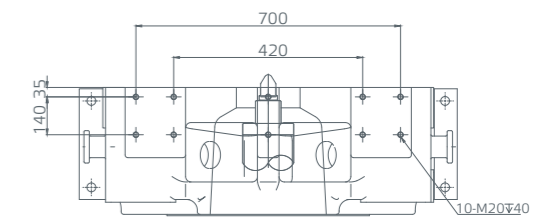

Moving platen dimension

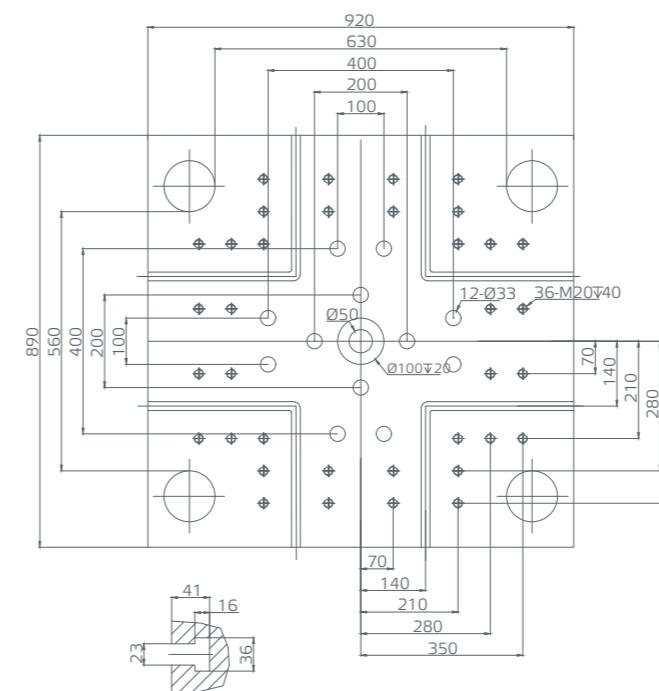

Feeding port dimensions

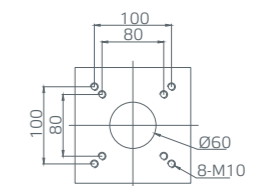

Clamping unit

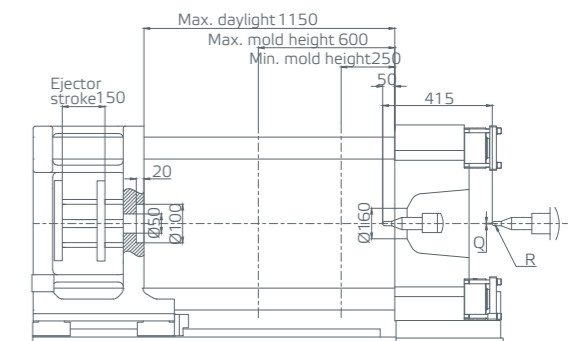

Injection unit	A	B	C	D	E	F	Q	R
e620/e620h	6245	5745	2070	1445	5515	6215	Ø3	SR10
e840/e840h	6782	6232	2221	1470	6015	6715	Ø4	SR15
e1100/e1100h	7030	6430	2221	1470	6015	6715	Ø4	SR15

Unit:mm

Parameters

Clamping unit		NEO-E320II								
Clamping force	kN	3200								
Clamping stroke	mm	600								
Space between tie bars	mm	730x660								
Max. mold height	mm	700								
Min. mold height	mm	280								
Ejector stroke	mm	150								
Ejector force	kN	134								
No. of ejector pins	piece	7								
Max. daylight	mm	1300								
Min. mold dimension	mm	510x460								
Platen dimensions (HxV)	mm	1050x1000								
Injection unit	Unit	e840			e1100			e1400		
		A	B	C	A	B	C	A	B	C
Screw diameter	mm	45	50	55	50	55	60	55	60	65
Screw L/D ratio	L/D	22.2	20.0	18.2	22.0	20.0	18.3	21.8	20.0	18.5
Shot size (theoretical)	cm ³	342	422	511	471	570	679	618	735	863
Injection weight (PS)	g	311	384	465	429	519	618	562	669	785
Injection pressure	MPa	247	200	165	224	185	155	220	185	158
	kgf/cm ²	2520	2040	1690	2280	1890	1590	2250	1890	1610
Holding pressure	MPa	198	160	132	179	148	124	176	148	126
	kgf/cm ²	2020	1630	1350	1830	1510	1270	1800	1510	1290
Injection rate into air (PS)	g/s	232	286	346	286	346	412	346	412	483
Screw speed	rpm	300			350			350		
Max. injection speed	mm/s	160			160			160		
Injection stroke	mm	215			240			260		
Nozzle contact force	kN	82			82			82		
Injection unit	Unit	e840h			e1100h			e1400h		
Injection rate into air	g/s	434	536	649	536	649	772	649	772	906
Max. injection speed	mm/s	300			300			300		
Others	Unit	e840/e840h			e1100/e1100h			e1400/e1400h		
Max. pump pressure	Mpa	17.5			17.5			17.5		
Pump motor power	kW	11			11			11		
Total power capacity	kW	61/75			62/92			74/104		
Heater power	kW	18.7			20.4			24.0		
Hopper capacity	kg	50			50			50		
Oil tank capacity	L	100			100			100		
Total machine weight	t	15			15.6			15.8		
Machine dimension (LxWxH)	m	7.1x1.9x2.4			7.2x1.9x2.4			7.2x1.9x2.4		

Remarks:

Shot size (theoretical) = Cross-sectional area of barrel(cm²) * injection stroke(cm)

Injection Weight = Shot size (theoretical)*0.91 (0.91 is the density of PS material)

Injection Weight and Injection rate into air is depends on material and parameters settings. The data in the table is for reference.

The injection pressure in the table is the maximum you can set. The truth data can be set as per your requirement.

Please inform us if you have requirement for engineering material like PVC, PMMA or some special requirement.

Due to continuous improvements, we reserve the right to modify any aspect of the specification without prior notice.

Front view of machine dimension

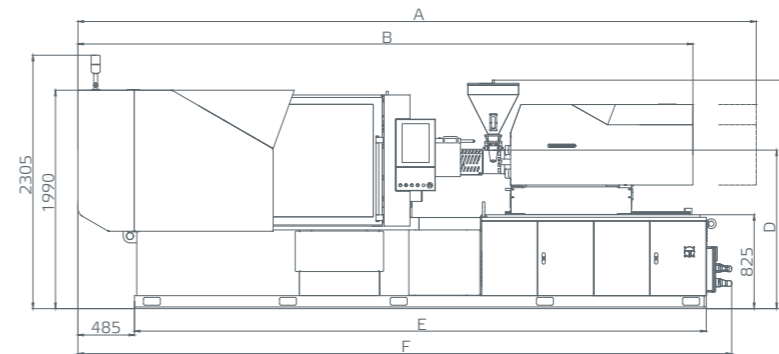

Robot installation dimension

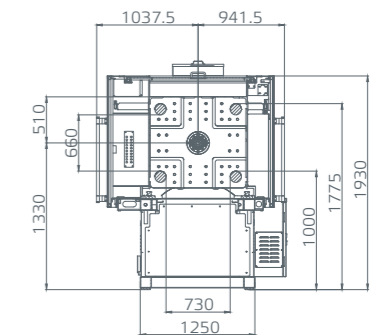

Top view of machine dimension

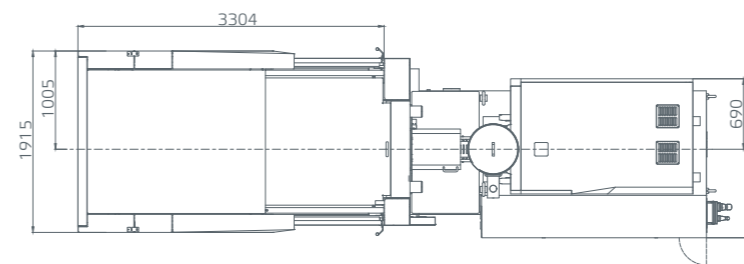

Robot fixed platen dimension

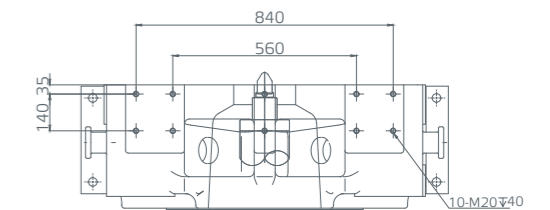

Moving platen dimension

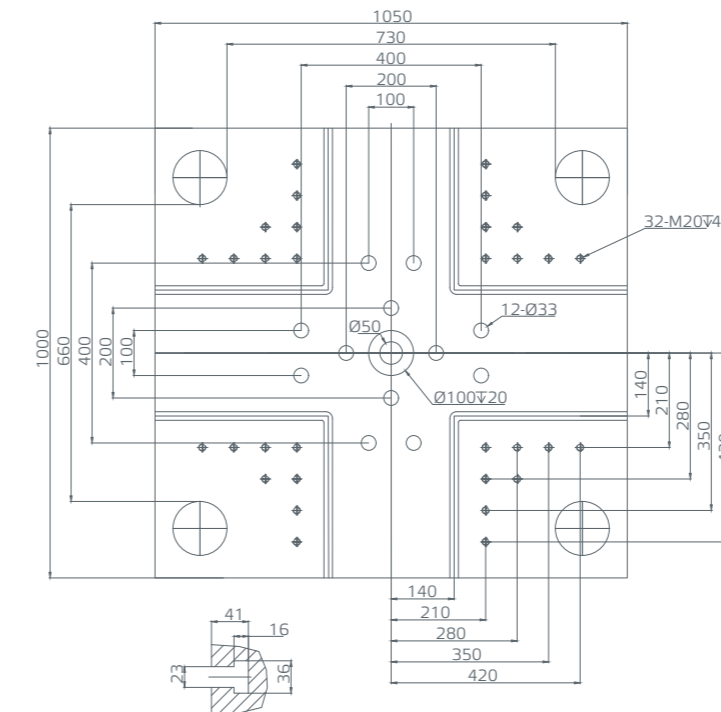

Feeding port dimensions

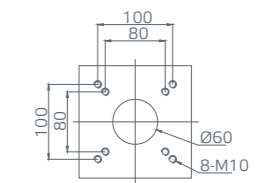

Clamping unit

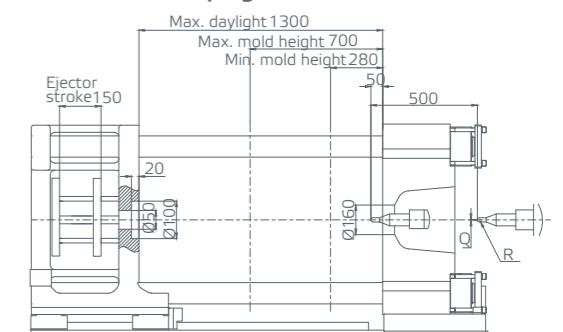

Injection unit	A	B	C	D	E	F	Q	R
e840/e840h	7128	6628	2211	1460	6415	7040	Ø4	SR15
e1100/e1100h	7330	6830	2221	1470	6515	7230	Ø4	SR15
e1400/e1400h	7438	6938	2221	1470	6515	7230	Ø4	SR15

Unit:mm

Parameters

Clamping unit		NEO-E470II								
Clamping force	kN	4700								
Clamping stroke	mm	800								
Space between tie bars	mm	910x810								
Max. mold height	mm	800								
Min. mold height	mm	320								
Ejector stroke	mm	180								
Ejector force	kN	134								
No. of ejector pins	piece	11								
Max. daylight	mm	1510								
Min. mold dimension	mm	635x565								
Platen dimensions (HxV)	mm	1300x1220								
Injection unit	Unit	e1400			e1700			e2300		
		A	B	C	A	B	C	A	B	C
Screw diameter	mm	55	60	65	60	65	70	65	70	80
Screw L/D ratio	L/D	21.8	20.0	18.5	21.7	20.0	18.6	21.5	20.0	17.5
Shot size (theoretical)	cm ³	618	735	863	792	929	1078	1078	1251	1634
Injection weight (PS)	g	562	669	785	720	846	981	981	1138	1487
Injection pressure	MPa	220	185	158	217	185	160	215	185	142
	kgf/cm ²	2250	1890	1610	2220	1890	1630	2190	1890	1450
Holding pressure	MPa	176	148	126	174	148	128	172	148	114
	kgf/cm ²	1800	1510	1290	1770	1510	1300	1750	1510	1160
Injection rate into air (PS)	g/s	346	412	483	412	483	560	483	560	643
Screw speed	rpm	350			300			250		
Max. injection speed	mm/s	160			160			160		
Injection stroke	mm	260			280			325		
Nozzle contact force	kN	82			82			82		
Injection unit	Unit	e1400h			e1700h					
Injection rate into air	g/s	649	772	906	643	755	876			
Max. injection speed	mm/s	300			250					
Others	Unit	e1400/e1400h			e1700/e1700h			e2300		
Max. pump pressure	Mpa	17.5			17.5			17.5		
Pump motor power	kW	16			16			16		
Total power capacity	kW	74/104			89/108			117		
Heater power	kW	24.0			28.4			33.0		
Hopper capacity	kg	50			50			50		
Oil tank capacity	L	100			100			150		
Total machine weight	t	24			24.5			25.5		
Machine dimension (LxWxH)	m	8.4x2.1x2.3			8.5x2.1x2.3			8.7x2.1x2.3		

Remarks:

Shot size (theoretical) = Cross-sectional area of barrel(cm²) * injection stroke(cm)

Injection Weight = Shot size (theoretical)*0.91 (0.91 is the density of PS material)

Injection Weight and Injection rate into air is depends on material and parameters settings. The data in the table is for reference.

The injection pressure in the table is the maximum you can set. The truth data can be set as per your requirement.

Please inform us if you have requirement for engineering material like PVC, PMMA or some special requirement.

Due to continuous improvements, we reserve the right to modify any aspect of the specification without prior notice.

Front view of machine dimension

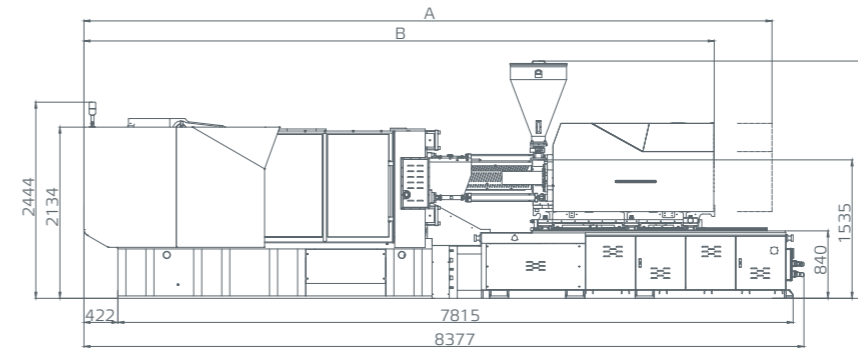

Robot installation dimension

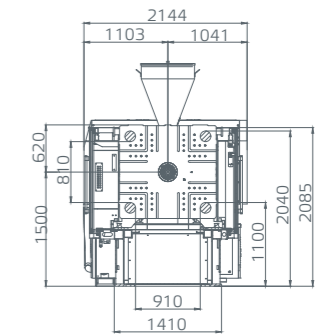

Top view of machine dimension

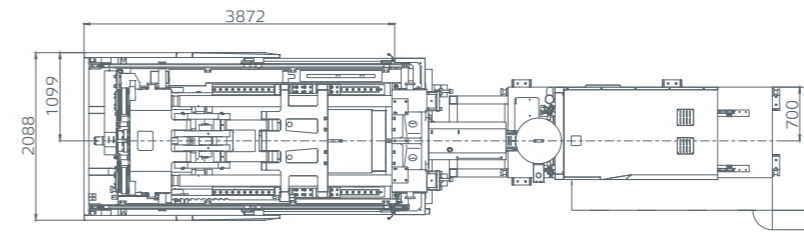

Robot fixed platen dimension

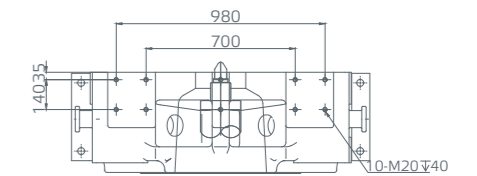

Moving platen dimension

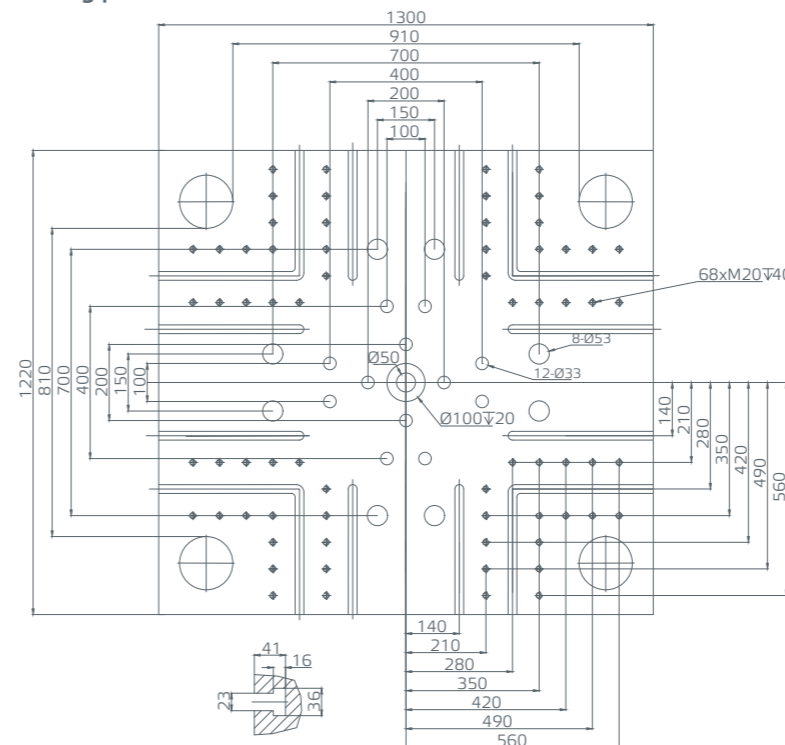

Feeding port dimensions

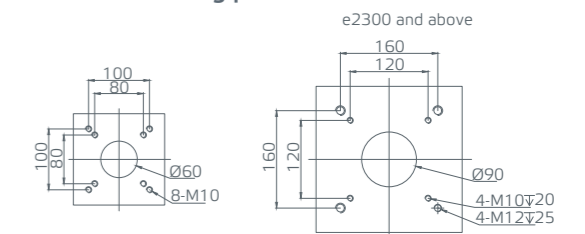

Clamping unit

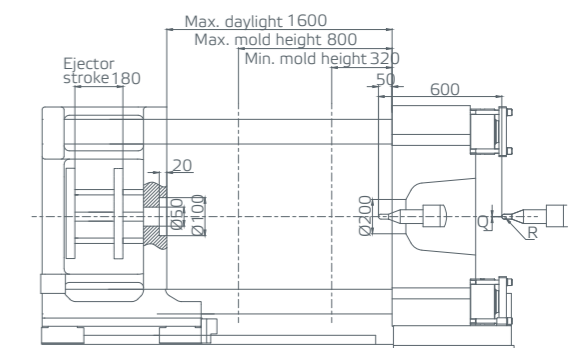

Injection unit	A	B	Q	R
e1400/e1400h	8065	7465	Ø4	SR15
e1700/e1700h	8504	7904	Ø4	SR15
e2300	8598	7998	Ø4	SR15

Unit:mm

Components & functions list

For clamping

Function description \ Clamping force	NEO-E60II- NEO-E90II	NEO-E120II- NEO-E200II	NEO-E260II- NEO-E470II	NEO-E560II- NEO-E850II	NEO-E1080II- NEO-E1400II
Platen with T slots	●	●	●	●	●
Platen with tapped holes	○	○	○	○	○
Platen(According to EUROMAP 2)	○	○	○	○	○
High rigid 5 points clamping unit	●	●	●	●	●
Mechanical & electrical safety	●	●	●	●	●
Hydraulic motor for mold heigh adjustment	○	●	●	●	●
Electric motor for mold heigh adjustment	●	○	○	○	○
Auto-mold height adjustment function	●	●	●	●	●
Second clamping adjustment function	○	○	○	○	○
Auto central lubrication system	●	●	●	●	●
High rigidity steel wear strips for moving platen				●	●
Overload line guide rail for moving platen	●	●	●	○	○
Mobile security lid for clamping unit	●	●	○	○	○
Auto safety door				○	●
Front safety door mechanical lock	●	●	●	●	●
Back safety door mechanical lock	○	○	○	○	○
Robot mechanical interface	●	●	●	●	●
Inlaid location ring	●	●	●	●	●
Mold protection	●	●	●	●	●
Eject pin return confirm	●	●	●	●	●
Ejection process checking connector	●	●	●	●	●
Six groups quick coupling of water regulator(10mm)	●	●			
Eight groups quick coupling for water regulator(10mm)	○	○	●		
Twelve groups of water regulator	○	○	○	●	●
Two air blow circuits	●	●	●	●	●
Glass water flow regulators	○	○	○	○	○
One group of hydraulic corepulling		●	●	●	●
Inclined plate for material feed-throat	○	○	○		
Products dropping test device	○	○	○		
Hydraulic ejection device		●	●	●	●
Electric ejection device	●	○	○		

● Standard ○ Optional

For injection

Function description \ Injection unit	e80-e220	e360-e1700	e2300	e3400-e9500
Standard screw	●	●	●	●
Special screw	○	○	○	○
Shut off nozzle	○	○	○	○
One line electric injection device	●	●	●	
Double screw electric injection device				●
Dual hydraulic cylinder base movement device		●	●	●
Electric adjustment device	●	○		
Screw rotating speed display	●	●	●	●
Electrical plasticizing	●	●	●	●
Temp-monitoring for material feeding throat	●	●	●	●
Injection screw temperature detection	●	●	●	●
Double barrel insulation cover	●	●	●	●
Nozzle cover	●	●	●	●
Auto centralized lubrication device	●	●	●	●
Ceramic heater band	●	●	●	●
Ball Screw mobile feed hopper	●	●	●	
Hopper dryer	○	○	○	○
Stainless hopper	●	●	●	●

● Standard ○ Optional

Components & functions list

For electric

Function description/ Clamping force	NEO·E60II-NEO·E120II	NEO·E160II-NEO·E1400II
KEBA controller	●	●
Memory with 200 sets of mold parameters	●	●
12"color touch display screen	●	
15"color touch display screen	○	●
All action instant monitoring	●	●
Production monitoring	●	●
Failure alarm display	●	●
Injection pressure turns holding pressure function	●	●
I/O monitoring interface	●	●
3 color light (with buzzer)	●	●
Motor overload protection	●	●
Front/back door emergency stop switch	●	●
5 pins socket of 380V/32A, two groups 5 pins socket of 380V/16A, one group 3 pins socket of 220V/16A, one group Socket of 220V/10A, one group"	●	●
EUROMAP 12 robot interface	●	●
EUROMAP 67 robot interface	○	○
Double protection for heating	●	●
Safety relay monitoring	●	●
SSR heating control	●	●
Central network control system	○	○
Hot runner control system & interface	○	○
Instant power consumption monitoring	●	●
Instant clamping force monitoring	○	○
Instant clamping force monitoring and self adjustment function	○	○
Injection pressure and speed in waveform display	●	●
Multiple languages switching	●	●
Preplasticizing Eject while mould open function	●	●
Coordinate heating	●	●
Anti cold start function	●	●
Auto residual material cleaning function	●	●

● Standard ○ Optional

For others

Function description/ Clamping force	NEO·E60II-NEO·E1400II
Tederic standard color	●
Shock-proof pad	●
Foundation steel plate, Foundation anchor bolts	○
Spare parts box, tools, mold, clamps, easy broken parts, and operation manual	●
Special color	○
Robot	○
Magnetic(for hopper dryer)	○
Chiller	○
Mould temp controller	○
Dehumidifier	○
Autoloader	○
Fumigate wood packaging	○
Products fetching platform	○

● Standard ○ Optional